

INDEX

SHEET NO.	SUBJECT
1	Terminal Joint Index and General Notes
2	Terminal Joint, Type PCCP
3	Terminal Joint, Type HMA

GENERAL NOTES:

1. When the approach pavement is Continuously Reinforced Concrete Pavement (CRCP) or HMA over CRCP, the details shall be as shown elsewhere on the plans.
2. The width of the concrete sleeper slab shall match the width of the reinforced concrete bridge approach slab.
3. Reinforcing bars shall be epoxy coated.
4. Sleeper slab and terminal joint shall be concrete, Class A.

INDIANA DEPARTMENT OF TRANSPORTATION

TERMINAL JOINT
INDEX AND GENERAL NOTES

SEPTEMBER 2021

STANDARD DRAWING NO. E 503-BATJ-01



	3/24/21
DESIGN STANDARDS ENGINEER	DATE
	3/29/2021
CHIEF ENGINEER	DATE

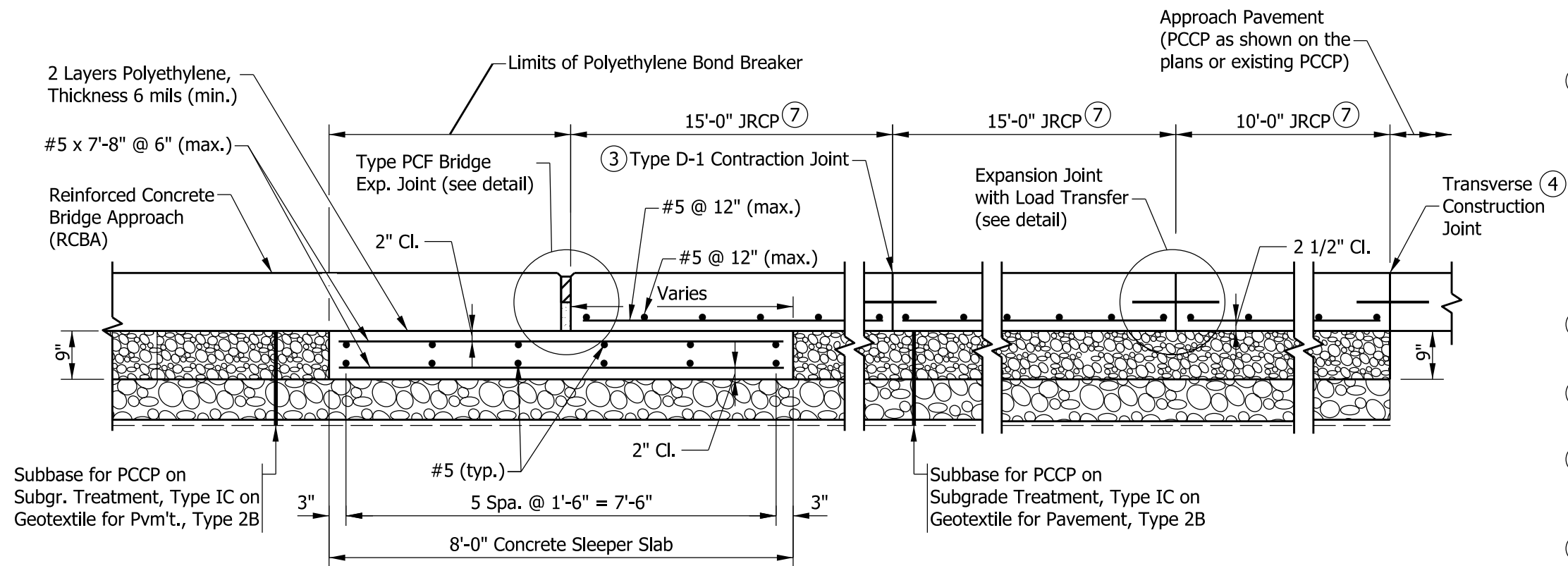

LONGITUDINAL SECTION

NOTES:

- ① The joint opening width shall be 2.5 in. for expansion lengths of 150 ft or less, regardless of the joint setting temperature. For expansion lengths greater than 150 ft, the joint opening width shall be constructed based on the actual ambient temperature at the time of construction with the manufacturer's joint setting table. The expansion length shall be as shown on the plans.
- ② The Type PCF Bridge Expansion Joint shall be able to accommodate both the minimum and maximum joint opening widths as shown below.
 - Expansion length 250 ft or less
W(min.)=1.3 in.
W(max.)=3.7 in.
 - Expansion length greater than 250 ft and less than 400 ft.
W(min.)=1.0 in.
W(max.)=4.0 in.
- ③ See Standard Drawing series E 503-CCPJ for type D-1 contraction joint details.
- ④ See Standard Drawing series E 503-CCPJ for transverse construction joint details.
- ⑤ Expansion cap shall be placed with an air gap of 1/4 in. min. between end of dowel bar and end of cap. Expansion caps shall be placed on alternating end of the dowel bar.
- ⑥ Tining or grooving of the concrete shall be terminated 6 in. in advance of the joint opening.
- ⑦ Jointed Reinforced Concrete Pavement (JRCP) thickness shall match the thickness of Reinforced Concrete Bridge Approach (RCBA).
8. Underdrains shall be constructed when shown on the plans.

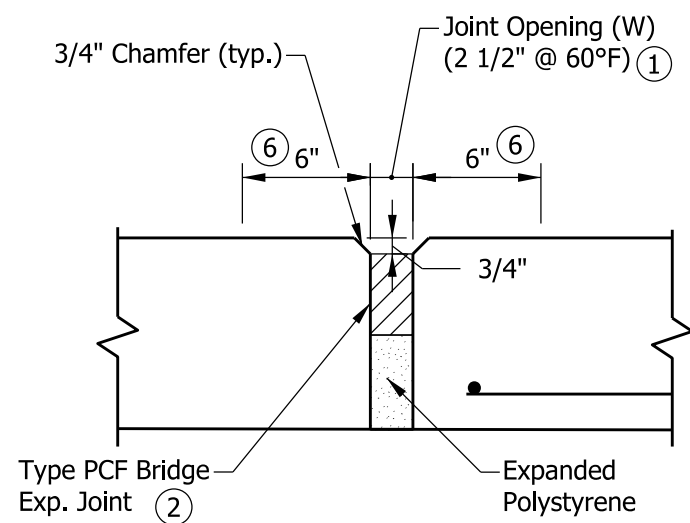

TYPE PCF BRIDGE EXPANSION JOINT DETAIL

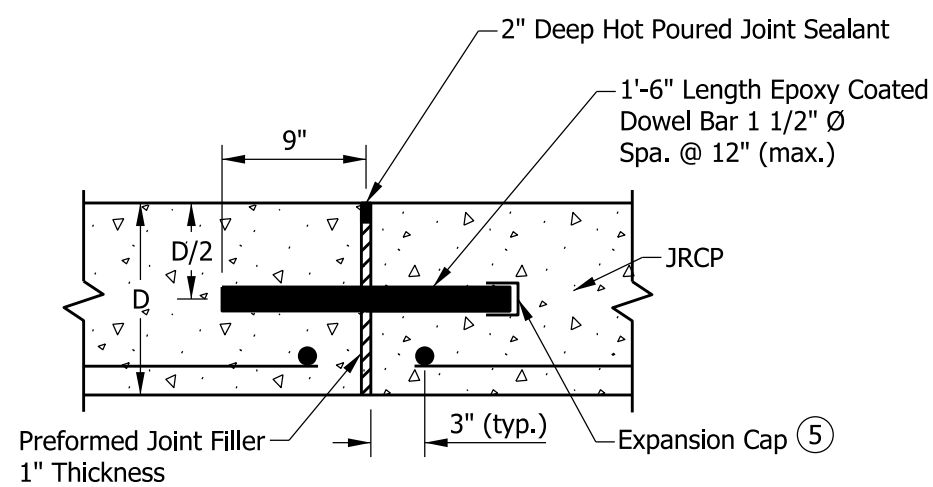

EXPANSION JOINT WITH LOAD TRANSFER DETAIL



INDIANA DEPARTMENT OF TRANSPORTATION

TERMINAL JOINT, TYPE PCCP

SEPTEMBER 2023

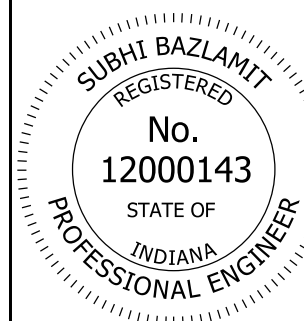
STANDARD DRAWING NO. E 503-BATJ-02



 4/04/23
 DESIGN STANDARDS ENGINEER DATE
 05/08/2023
 CHIEF ENGINEER DATE

NOTES:

- ① The joint opening width shall be 2.5 in. for expansion lengths of 150 ft or less, regardless of the joint setting temperature. For expansion lengths greater than 150 ft, the joint opening width shall be constructed based on the actual ambient temperature at the time of construction with the manufacturer's joint setting table. The expansion length shall be as shown on the plans.
- ② The Type PCF Bridge Expansion Joint shall be able to accommodate both the minimum and maximum joint opening widths as shown below.
 - Expansion length 250 ft or less
W(min.)=1.3 in.
W(max.)=3.7 in.
 - Expansion length greater than 250 ft and less than 400 ft
W(min.)=1.0 in.
W(max.)=4.0 in.
- ③ Pavement section to be shown on the plans.
Minimum Thickness:
 - 15 in. HMA for 12 in. RCBA
 - 13 in. HMA for 10 in. RCBA
- ④ Tining or grooving of the concrete shall be terminated 6 in. in advance of the joint opening.

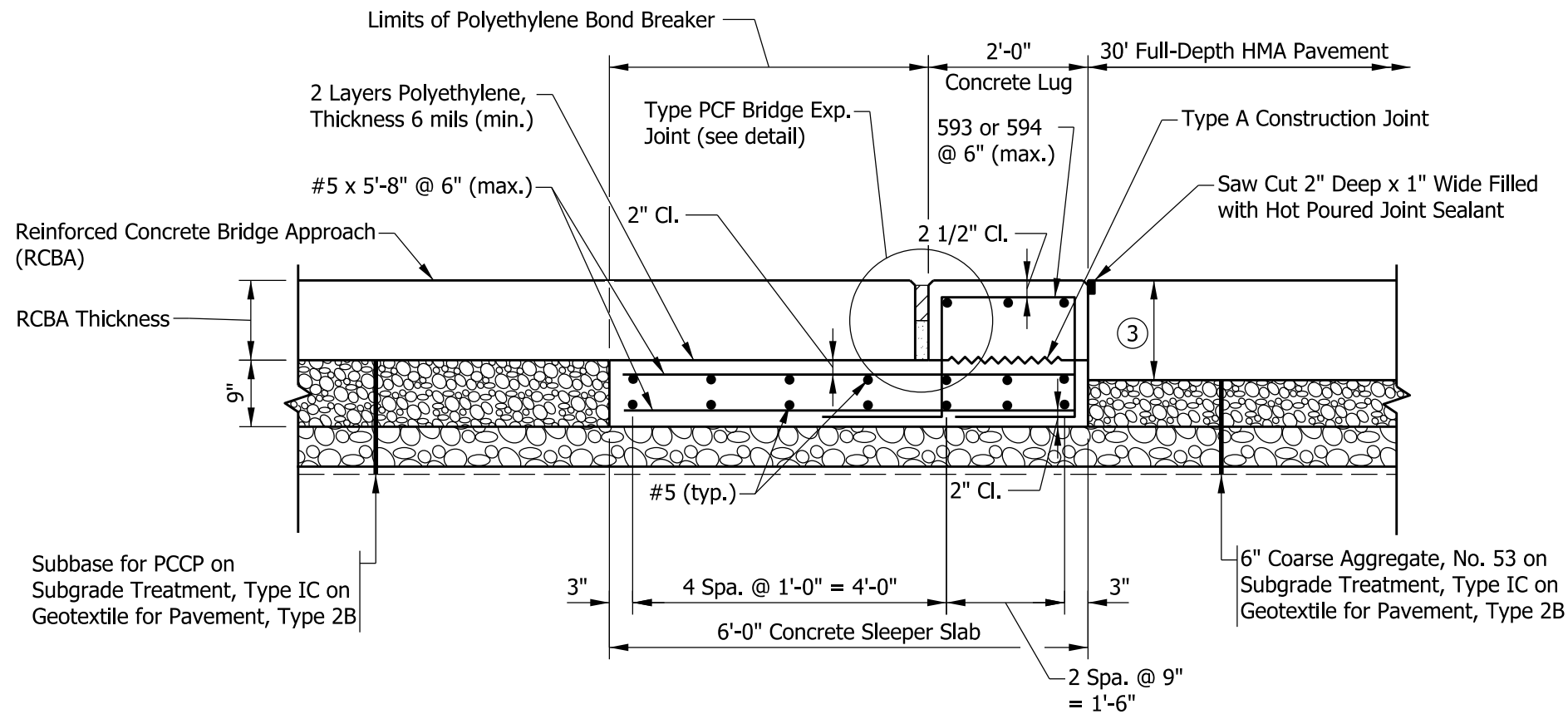

LONGITUDINAL SECTION

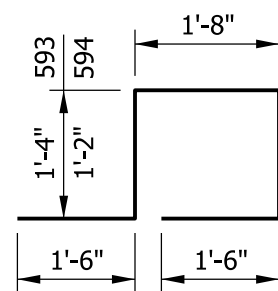

593 x 7'-4" (for 12" RCBA)
594 x 7'-0" (for 10" RCBA)

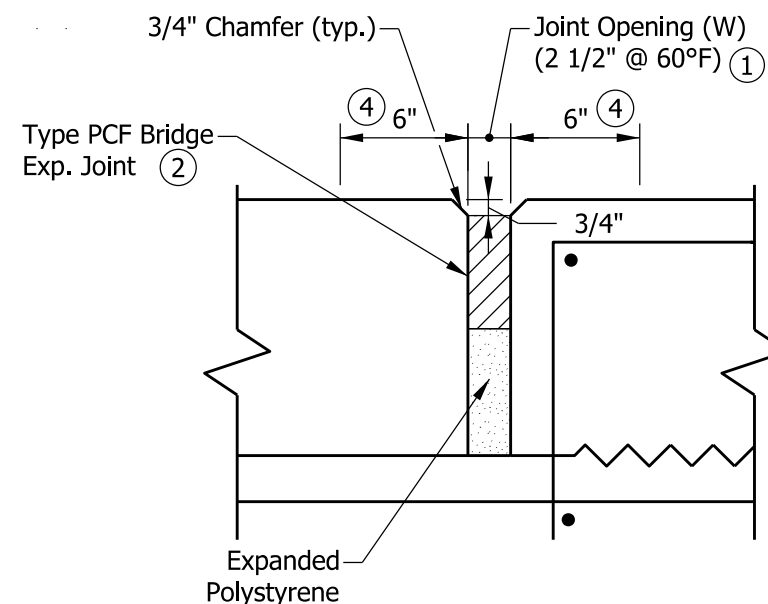

TYPE PCF BRIDGE EXPANSION JOINT DETAIL

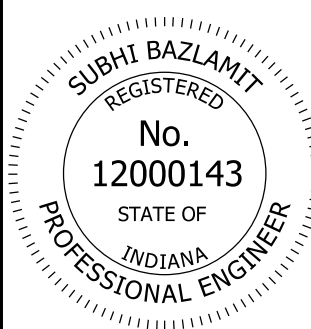
INDIANA DEPARTMENT OF TRANSPORTATION	
TERMINAL JOINT, TYPE HMA	
SEPTEMBER 2023	
STANDARD DRAWING NO.	E 503-BATJ-03
	<p style="text-align: right;"><i>Subhi Bazlamit</i> 4/04/23</p> <p style="text-align: right;">DESIGN STANDARDS ENGINEER DATE</p> <hr/> <p style="text-align: right;"><i>[Signature]</i> 05/08/2023</p> <p style="text-align: right;">CHIEF ENGINEER DATE</p>